



MASTERFLEX® B/T® Pump 77110-00

OPERATING MANUAL:
**B/T® RAPID-LOAD
FIXED SPEED
PERISTALTIC PUMPS
AND DRIVE**

Model No.

77110-00

77110-07

A-1299-5124
Edition 02



Cole-Parmer

1-800-MASTERFLEX (627-8373) (U.S. and Canada only) • 11 (847) 549-7600 (Outside U.S.)
(847) 549-7600 (Local) • www.masterflex.com • techinfo@coleparmer.com

Thermo Fisher Scientific

1-800-637-3739 (U.S. and Canada only) • 11 (847) 381-7050 (Outside U.S.)
(847) 381-7050 (Local) • www.thermo.com • bar.barnant@thermofisher.com



TABLE OF CONTENTS

Title	Page
SAFETY PRECAUTIONS	3
INTRODUCTION	4
APPLICATION DATA	4
GENERAL DESCRIPTION	4
INSTALLATION AND SETUP	5
TUBING TYPES	6
INSTALLING THE PUMP TUBING	6
REPLACING ROLLERS	8
OPERATION	8
MAINTENANCE	9
Replacement Parts	9
Cleaning	9
ACCESSORIES	9
SPECIFICATIONS	10
WARRANTY	12
PRODUCT RETURN	12
TECHNICAL ASSISTANCE	12

B/T, PERFECTPOSITION – Reg TM Thermo Fisher

C-FLEX – Reg TM Consolidated Polymer Technologies, Inc.

NORPRENE, PHARMAPURE, PHARMED and TYGON – Reg TM Saint-Gobain Performance Plastics Corp.

Trademarks bearing the ® symbol in this publication are registered in the U.S. and in other countries.

SAFETY PRECAUTIONS

DANGER: *High voltages exist and are accessible. Do not remove cover of Drive. Use extreme caution when servicing internal components.*



CAUTIONS: *Risk of electric shock – this pump is supplied with a grounding conductor and grounding-type attachment plug. To reduce risk of electric shock, be certain that it is connected only to a properly grounded, grounding-type receptacle.*



Electrical connections and grounding (earthing) must conform to local wiring codes.

WARNINGS: *Tubing breakage may result in fluid being sprayed from pump. Use appropriate measures to protect operator and equipment.*



Power must be removed from pump before removing or installing tubing. Fingers or loose clothing could get caught in drive mechanism. Do not operate this pump without cover or interlock door properly closed and latched. Rotating parts can cause serious injury.

To reduce risk of injury, do not pump materials hotter than 150 degrees Fahrenheit, (65.5°C).

Explanation of Symbols

CAUTION: *Risk of Danger. Consult Operator's manual for nature of hazard and corrective actions.*



CAUTION: *Risk of crushing. Keep fingers away from rotor while pump is in operation. Stop pump before loading or unloading tubing.*



CAUTION: *Hot Surface. Do not touch.*



CAUTION: *Risk of electric shock. Consult Operator's manual for nature of hazard and corrective actions.*



WARNING: PRODUCT USE LIMITATION

This product is not designed for, nor intended for use in, patient-connected applications, including, but not limited to, medical and dental use, and, accordingly, has not been submitted for FDA approval. If drive is used in a manner not specified in this manual the protection provided by the equipment may be impaired.

INTRODUCTION

This manual provides information for installing, operating and servicing the following models of MASTERFLEX® B/T® RAPID-LOAD peristaltic pumps.

MODEL TYPE

77110-00 Fixed Speed w/TEFC, 115V AC @ 60 Hz

77110-07 Fixed Speed w/TEFC, 230V AC @ 50 Hz

The unique design of these peristaltic pumps provides a greatly simplified means for rapid loading and changing of tubing. In addition, different sizes and formulations of tubing can be used. Unlike many older type pumps where tubing had to be carefully measured and tubing connectors were mandated, this pump provides for the use of a continuous piece of tubing to ensure sanitary connections. Fluid contacts only the tubing and fittings. These pumps are designed to handle a wide range of viscosities and can pump up to 10 GPM.

APPLICATION DATA

The gentle peristaltic action of these pumps is ideal for pumping highly viscous and shear-sensitive liquids. These pumps are also ideally suited for use where sterile conditions and purity are required. Toxic and hazardous fluids can be pumped with the proper selection of MASTERFLEX PERFECTPOSITION B/T tubing since the fluid contacts only the tubing and not the pump.

WARNING: *Tubing breakage may result in fluid being sprayed from pump. Use appropriate measures to protect operator and equipment.*



GENERAL DESCRIPTION

Due to its unique design, different MASTERFLEX PERFECTPOSITION B/T tubing sizes can be accommodated by this RAPID-LOAD peristaltic pump.

For an indirect estimate of flow rate, a reflective element attached to the rotor has been provided for use with an optical tachometer. Point tachometer beam through front cover window and target the reflective element.

To obtain flow rate in mL/min., multiply tachometer rpm reading times the nominal flow per revolution value provided in TABLE 1 (**Note:** 3,785 mL = 1 U.S. liquid gallon).

If the pump is to be operated with back-pressure on the discharge line above 5 PSIG, hose clamps or screw-type band clamps are recommended on the tubing connections on the discharge side of the pump. Silicone or C-FLEX® tubings, because of their highly elastic natures, can expand very quickly if back-pressure is present and could create leakage at the fittings if not securely retained. It is this same elastic nature, however, that makes them such excellent materials for this peristaltic type pump and give it its long life. NORPRENE® tubing yields longer life especially under pressure. Do not attempt to use other materials in lieu of these, as pump performance could be severely compromised with possible damage to the pump. Refer to TABLE 1 for tubing recommendations.

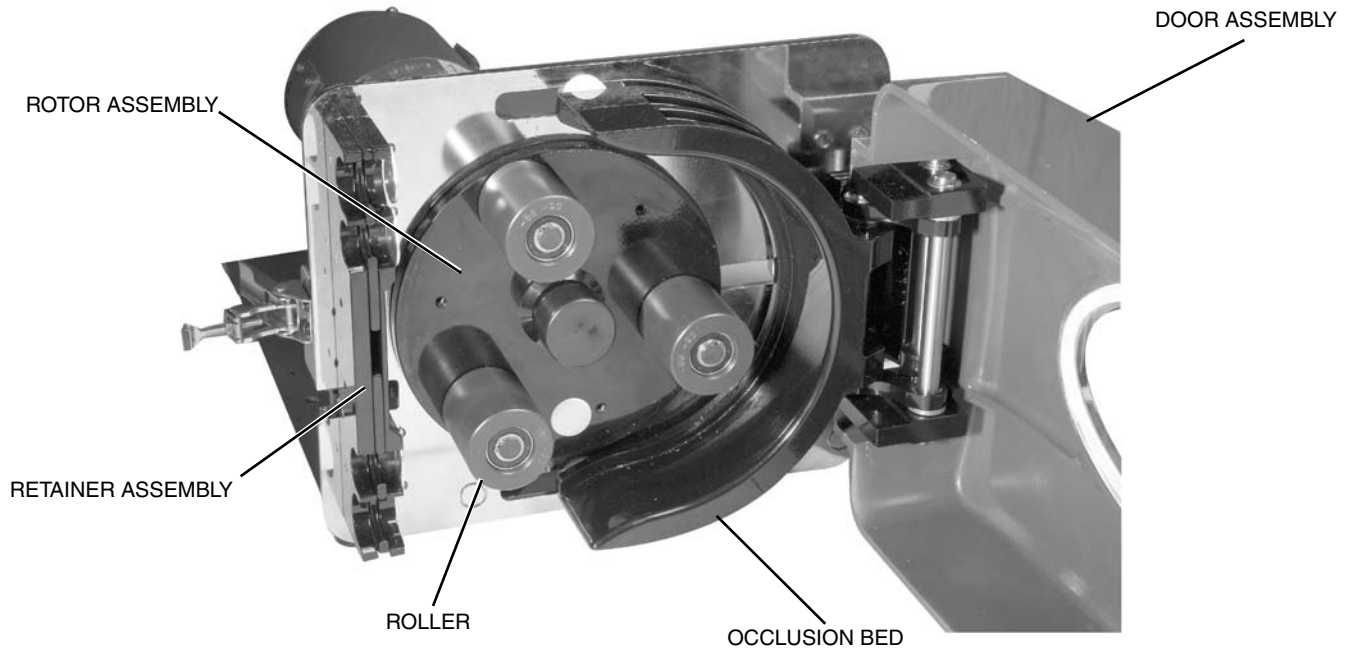
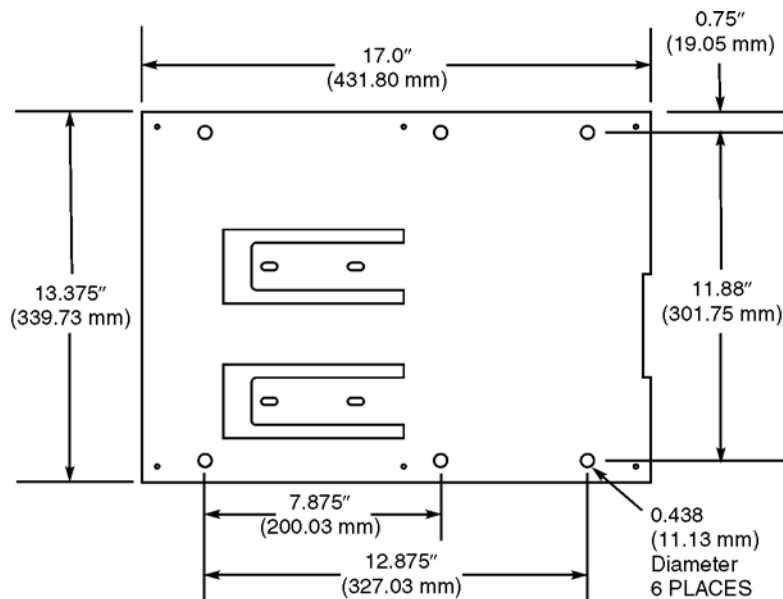

Figure 1. RAPID-LOAD PUMP ASSEMBLY

INSTALLATION AND SETUP

Models 77110-00 and 77110-07 are shipped complete. These models should be placed on a flat surface such as a floor, bench or table and should be near an electrical power source. (See below for mounting dimensions.) Be sure to check data plate for proper voltage rating(s).



TUBING TYPES

Use only MASTERFLEX *PERFECTPOSITION* B/T precision tubing with MASTERFLEX pumps to ensure optimum performance.

Use of other tubing may void applicable warranties.

NOTE: Use MASTERFLEX *PERFECTPOSITION* B/T tubing. These pumps are designed to use B/T tubing sizes 87 and 91 only. The tubing sizes refer to the last two digits of the MASTERFLEX *PERFECTPOSITION* B/T tubing model number.

The following chart provides information for the various sizes of tubing.

Table 1

Characteristics	Tubing Size	
	B/T 87	B/T 91
Inside Dia. in (mm)	0.5 (12.7)	0.75 (19.05)
Outside Dia. in (mm)	1.0 (25.4)	1.25 (31.8)
Hose barb size in (mm)	1/2" (12.7)	3/4" (19.0)
Flow Range (with 321 rpm drive)	0.17-5.0 GPM (0.010-18.9 L/m)	0.37-10 GPM (1.40-37.85 L/m)
Nominal Flow Per Revolution	70.46 mL	141 mL
Maximum Vacuum	28.5 in Hg	32 in Hg
Maximum: Outlet Pressure	35 psi	30 psi
Flow ranges are approximate - calculated under the following conditions: 0 psi at inlet, 0.5 psi at outlet and water circulant at 72°F (22° C).		

INSTALLING THE PUMP TUBING

WARNING: *Power must be removed from pump before removing or installing tubing. Fingers or loose clothing could get caught in drive mechanism. Do not operate this pump without cover or interlock door properly closed and latched. Rotating parts can cause serious injury.*



1. Cut off power to the pump by disconnecting line cord or, if wired permanently, by removing the fuse. Do not assume that turning off the switch at the motor (or controller) is "safe enough."
2. Unlatch the locking clamp and open the cover.
3. Insert the tube in the appropriate upper tube retaining pocket (see Figure 2). Line up the "*PERFECTPOSITION*" placement marks printed on the tube with the outside edge of the retainer assembly (see Figure 3).
4. Wrap the tubing around the rotor assembly and insert the tubing in the lower retaining pocket.
5. Close the cover and re-latch the locking clamp.
6. If the new tube must be cut from a length of approved replacement tubing, a minimum of 32 inches will be required for a new tube.

WARNING: *Do not operate this pump without cover or interlock door properly closed and latched. Rotating parts can cause serious injury.*



7. Restore power to the pump.

NOTE: Under some circumstances, tubing may creep into pump. If this problem occurs it can be remedied by installing a hose clamp or fitting immediately upstream of the upper retaining pocket.

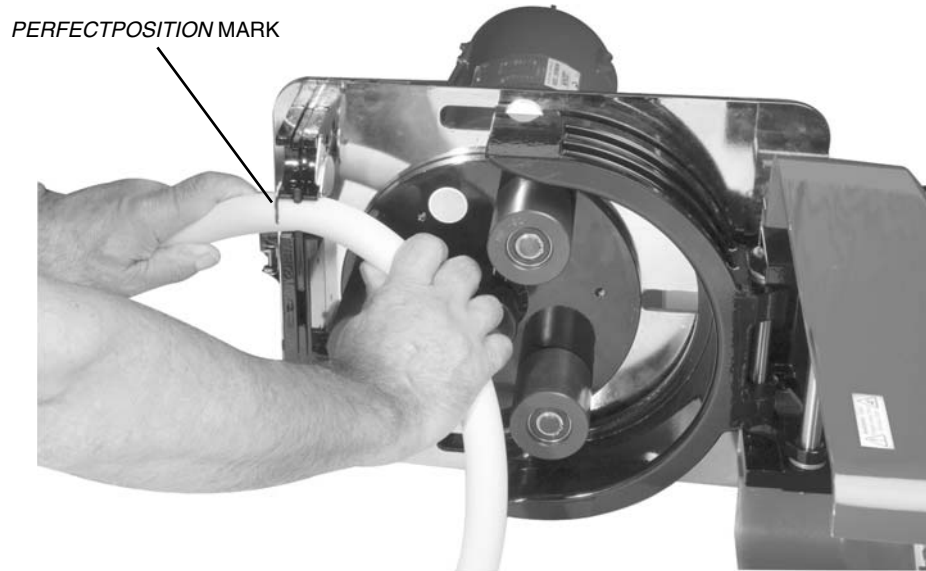

Figure 2. TUBING RETAINING POCKETS

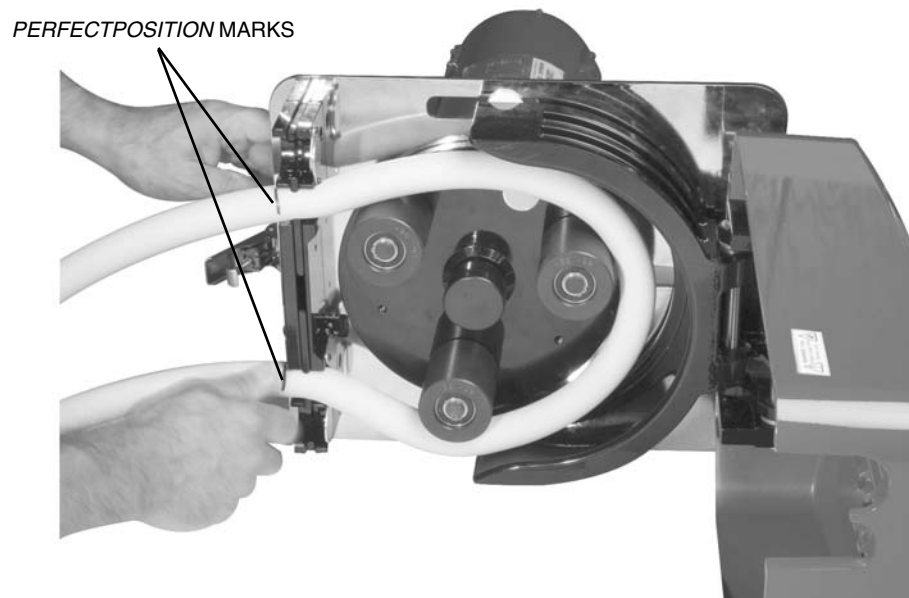
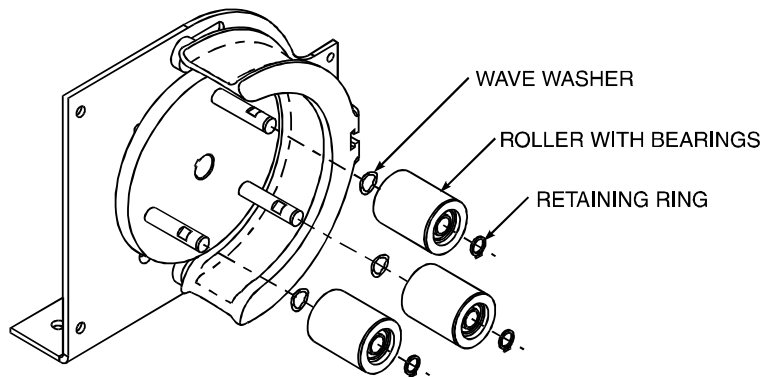

Figure 3. PERFECTPOSITION MARKS

REPLACING ROLLERS

To replace rollers:

1. Using a retaining ring tool (Part Number 07585-06), remove the retaining rings from the ends of the roller axles and slide the rollers off. Take care to avoid opening the retaining rings too wide.
2. Check to be sure that the wave washers are installed on the axles against the rotor plate.
3. Slide the new rollers, Replacement Roller Kit 07584-02, onto the axles, placing the ends with the flush bearing surface inward toward the rotor plate against the wave washers, and the etched ends with the recessed bearing surface outward toward the free ends of the roller axles.
4. Replace the retaining rings. You may have to push the rollers in to compress the wave washers to allow the retaining rings to engage the grooves in the axles.



EXPLODED ROLLER SUB-ASSEMBLY

OPERATION

The following chart highlights items included in each model and the operating controls.

Model No.	Motor Included	ON-OFF Switch
77110-00	Yes	Yes
77110-07	Yes	Yes

MAINTENANCE

Replacement Parts

The following list identifies the replaceable parts and includes the part numbers.

Description	Part Number	Qty per Unit
Rubber feet Kit (6 screws)	108655-CR	6
MASTERFLEX B/T Roller Kit	07584-02	1
MASTERFLEX B/T Rotor Assembly/with rollers	108024-CR	1
Door Assembly	108175-CR	1
Window	108179-CR	1
Window Gasket	108183-CR	1
Shoulder Spacer Kit	108692-CR	3
Safety Switch Assy	108173-CR	1
Fuse - T10A, 5 x 20mm, (115V AC)	77500-29	1
Fuse - T6.3A, 5 x 20mm, (230V AC)	77500-24	1
Motor (115V AC)	108454-CR	1
Motor (230V AC)	108455-CR	1
Motor Mounting Hardware	108688-CR	1
Retaining Ring Kit	07584-07	1
Line Cord - European (230V)	50001-70	1

Cleaning

Keep the drive enclosure clean with mild detergents. Never immerse nor use excessive fluid.

ACCESSORIES

All MASTERFLEX *PERFECTPOSITION* B/T tubing formulations in sizes 87 and 91 can be used with this pump. Be sure tubing material matches application.

Description	Part Number		
Retaining Ring Tool	07585-06		
Extension Cable, 25 ft.	108344-CR		
<i>PERFECTPOSITION</i> Pump Tubing		B/T 87	B/T 91
Silicone - 10 ft. (3.0 m), Platinum cured		96510-87	96510-91
Silicone - 10 ft. (3.0 m), Peroxide cured		96400-87	96400-91
BioPharm silicone - 25 ft. (7.6 m), Platinum cured		96422-87	96422-91
BioPharm Plus silicone - 25 ft. (7.6 m), Platinum cured		96442-87	96442-91
C-FLEX - 10 ft. (3.0 m)		06424-87	06424-91
PharMed® BPT - 25 ft. (7.6 m)		06508-87	06508-91
PharMed® BPT - 3 ft. (0.9 m)		95668-87	95668-91
PharmaPure® - 25 ft. (7.6 m)		06435-87	06435-91
NORPRENE® food - 25 ft. (7.6 m)		06402-87	06402-91
NORPRENE® food - 3 ft. (0.9 m)		06403-87	06403-91
TYGON® LFL - 25 ft. (7.6 m)		06429-87	06429-91
TYGON® LFL - 3 ft. (0.9 m)		06430-87	06430-91

SPECIFICATIONS

Output:

Pump Speed:

Model 77110-00	321 rpm
Model 77110-07	271 rpm

Torque output, maximum:

Model 77110-00, -07	1100 oz-in (104 kg-cm)
---------------------	------------------------

Tubing compatibility: Sizes 87 or 91

Flow Range: Up to 10 GPM (37.85 LPM)

Input:

Supply voltage limits:

Model 77110-00	90 to 130 Vrms @ 60 Hz
Model 77110-07	200 to 260 Vrms @ 50 Hz

Current, max:

Model 77110-00	8.0A
Model 77110-07	4.0A

Construction:

Dimensions (W × H × D):

Model 77110-00, -07	16-1/2 in × 11-5/8 in × 24 in (41.91 cm × 29.53 cm × 60.96 cm)
---------------------	---

Weight:

Model 77110-00, -07	88 lbs (39.9 kg)
---------------------	------------------

Environment:

Operating Temperature: 0°C to 40°C (32°F to 104°F)

Storage Temperature: -10°C to 60°C (-14°F to 140°F)

Enclosure Rating:

Model 77110-00, -07	IP65 per IEC 60529
---------------------	--------------------

Humidity:

(non-condensing) 10% to 90%

Altitude: Less than 2000 m

Pollution Degree: Degree 3 per EN 61010-1 (Sheltered Locations)

Chemical Resistance: Exposed material is painted aluminum, plastic and vinyl

Compliance: 115V: UL778, CSA C22.2 No. 108
230V: (for CE mark)
EU Low Voltage Directive (EN61010-1)
EU EMC Directive (EN61326)
EU Machinery Directive (EN809)

Notes . . .

WARRANTY

Use only MASTERFLEX PERFECTPOSITION B/T precision tubing with MASTERFLEX pumps to ensure optimum performance. Use of other tubing may void applicable warranties.

The Manufacturer warrants this product to be free from significant deviations from published specifications. If repair or adjustment is necessary within the warranty period, the problem will be corrected at no charge if it is not due to misuse or abuse on your part, as determined by the Manufacturer. Repair costs outside the warranty period, or those resulting from product misuse or abuse, may be invoiced to you.

The warranty period for this product is two (2) years from date of purchase.

PRODUCT RETURN

To limit charges and delays, contact the seller or Manufacturer for authorization and shipping instructions before returning the product, either within or outside of the warranty period. When returning the product, please state the reason for the return. For your protection, pack the product carefully and insure it against possible damage or loss. Any damages resulting from improper packaging are your responsibility.

TECHNICAL ASSISTANCE

If you have any questions about the use of this product, contact the Manufacturer or authorized seller.



Cole-Parmer

1-800-MASTERFLEX (627-8373) (U.S. and Canada only)
11 (847) 549-7600 (Outside U.S.)
(847) 549-7600 (Local)
www.masterflex.com
techinfo@coleparmer.com



Thermo Fisher Scientific
1-800-637-3739 (U.S. and Canada only)
11 (847) 381-7050 (Outside U.S.)
(847) 381-7050 (Local)
www.thermo.com
bar.barnant@thermofisher.com

